

Undocumented: The Architecture of Migrant Detention

Tings Chak

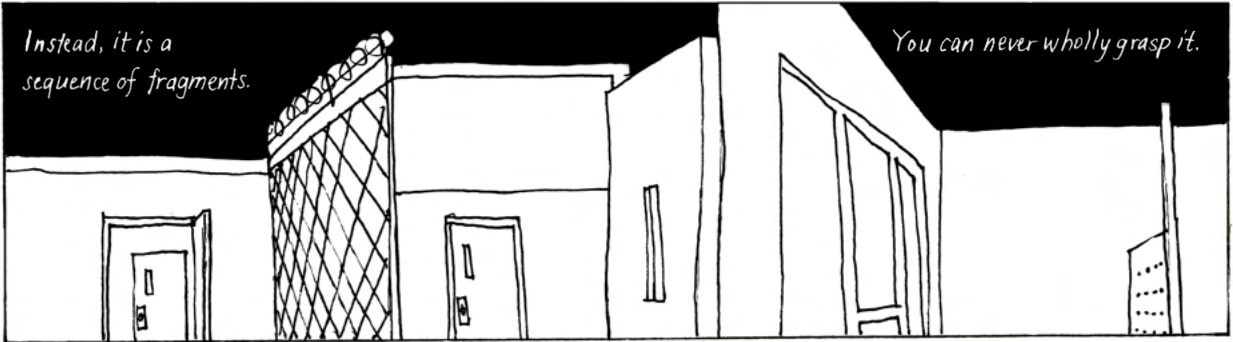

Based on description by Susan Rosenberg, interviewed by Brett Story in CBC Ideas "Alone Inside" (2013)



*Instead, it is a
sequence of fragments.*

You can never wholly grasp it.

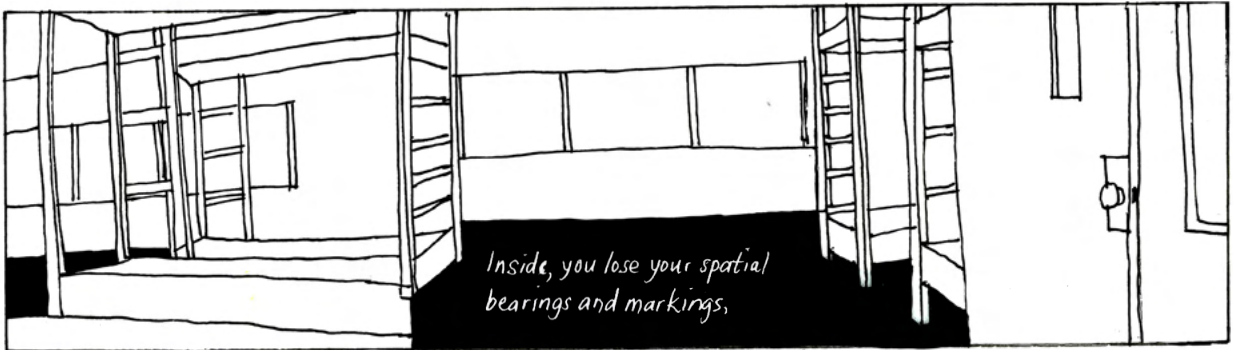
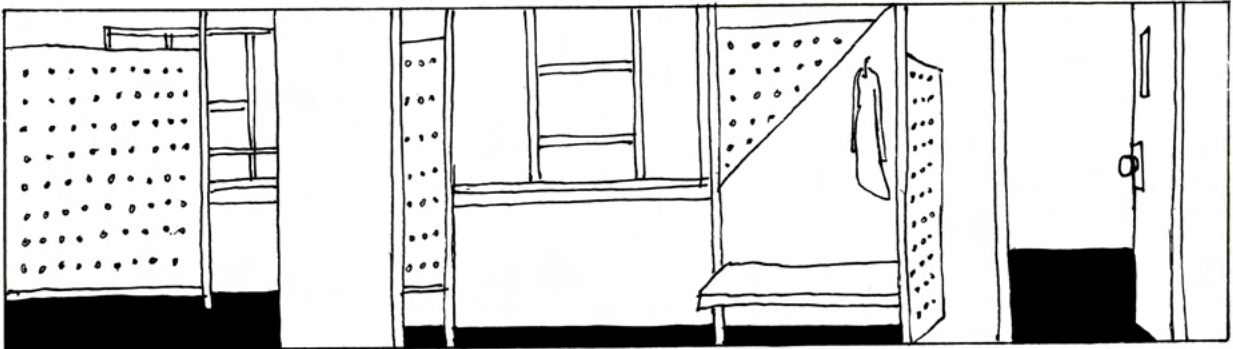

*Inside, you lose your spatial
bearings and markings,*

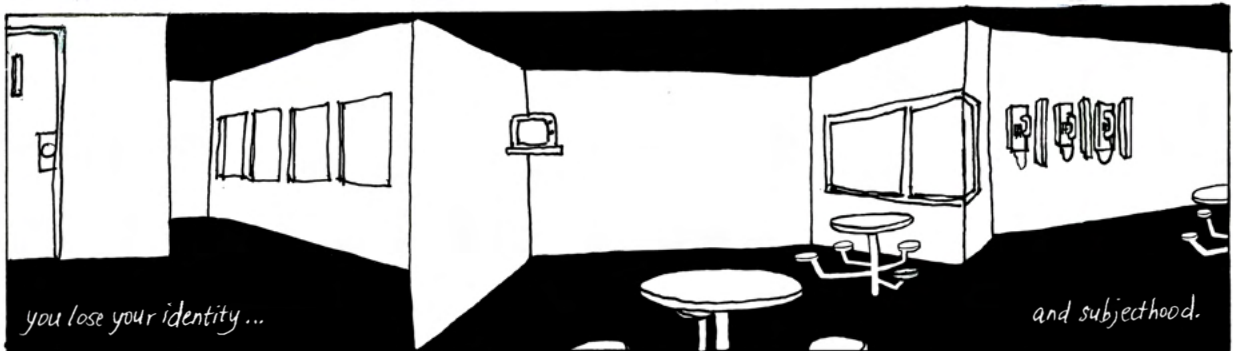

you lose your identity...

and subjecthood.

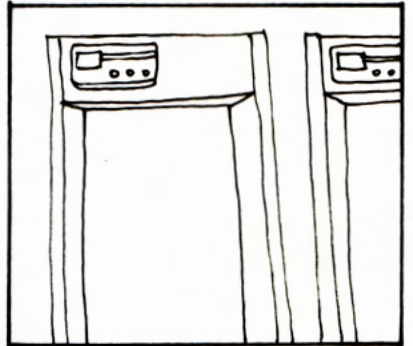
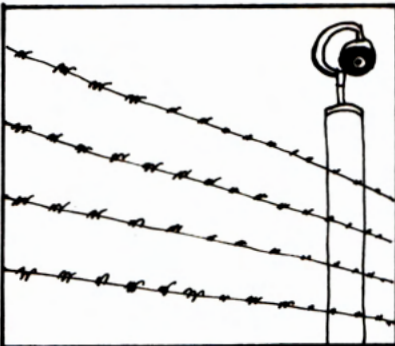
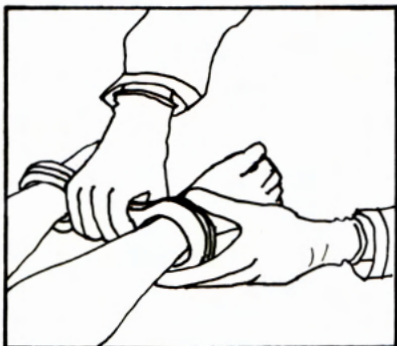
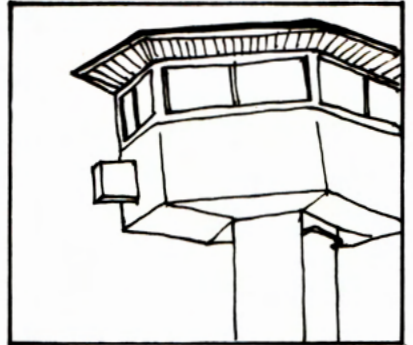
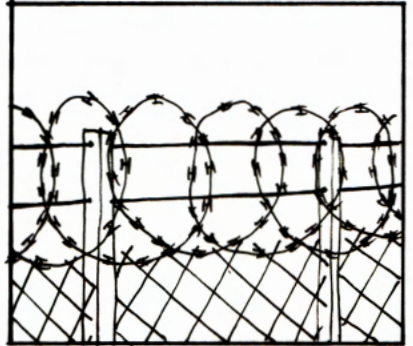
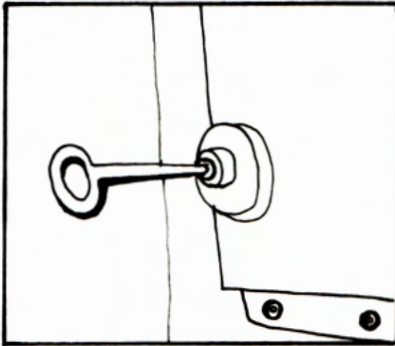
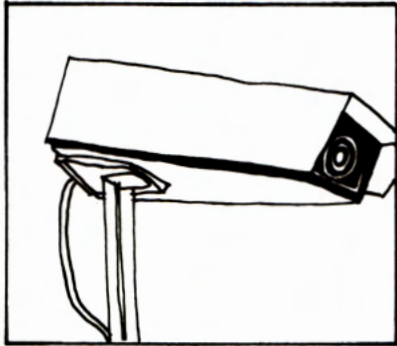

There are billions of dollars made in the incarceration of human bodies. There are a lot of hands involved in this industry, but there aren't many faces. In these authorless spaces, we hide the casualties of poverty and displacement, we even try to hide the spaces themselves. It is a tyranny without a tyrant, where nobody rules and we are all equally powerless.²

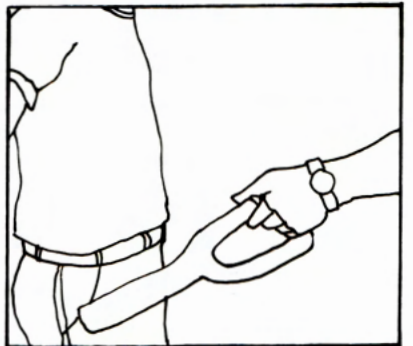

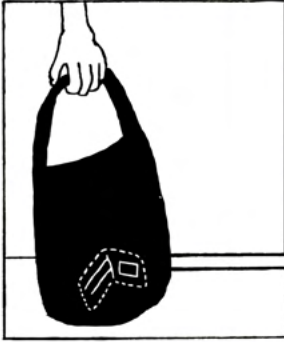

Status is a fickle thing.
it can be taken away from you,
and at any moment,
it can be lost.



It determines
your identity,
your rights,
your access,
your freedom.

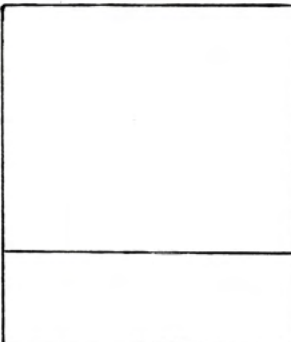
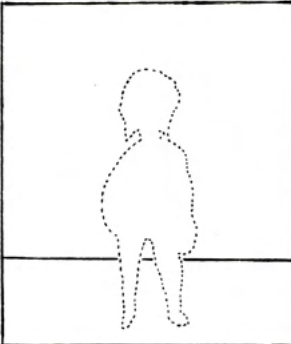

IDENTIFICATION	
	<u>NAME/ NOM</u> Wang, Fang
	<u>ADDRESS</u> 442 Newderry Street, Apt. 201
	<u>NATIONALITY/ NATIONALITÉ</u> <u>SEX/SEXE</u> Chinese F
	<u>PLACE OF BIRTH/ LIEU DE NAISSANCE</u> Shenzhen
	<u>DATE OF BIRTH/ DATE DE NAISSANCE</u> 31 July 1972

But your name is more than a series of romanized letters, phonetically transcribed that, when uttered, can never capture its weight.

It can never come close to the language your given name was given in.

Your place of birth has nothing to do with the treachery of borders, violently imposed onto our bodies, between our families, and throughout the places we call home.



*You are not a minor, a senior, or a dependent,
but you are an elder, a lover, and a child.*

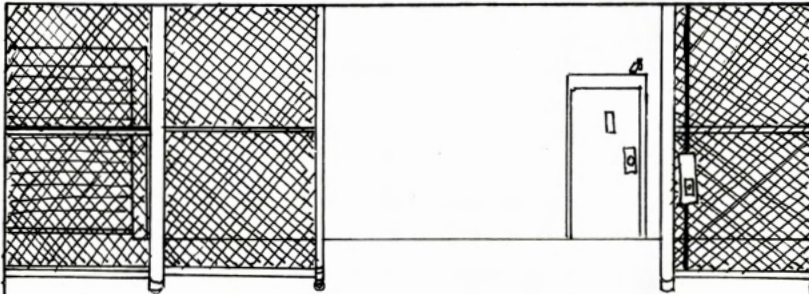

Each morning, a school bus drives up to the immigration detention centre.³

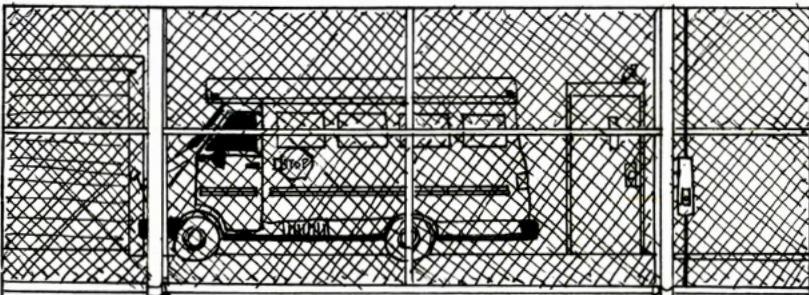
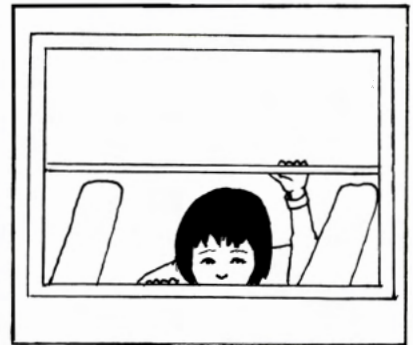

Behind barbed wire and a security gate, children board the bus.

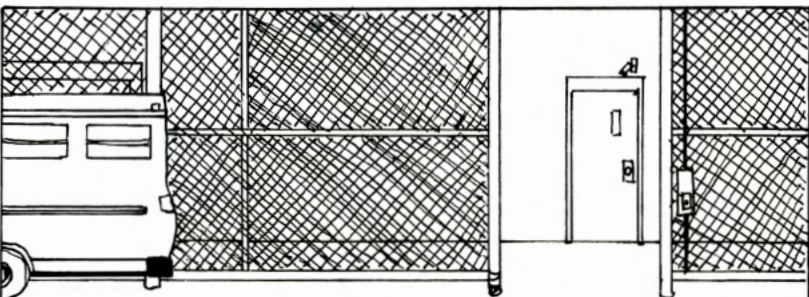

It becomes a ritual that spells trauma.



There is an immigration detainee on hunger strike for over sixty days in protest of indefinite detention. Held for 28 months in a maximum security prison without charge or trial, he said, "I missed three of my sons birthdays, I missed three anniversaries with my wife... I cannot see myself here being detained indefinitely and thinking about them. That will drive me crazy. So I have to keep it out of sight and out of mind. How inhumane is that?"

"I am a father and I am a husband."



"Should I even be allowed to feel like this?"

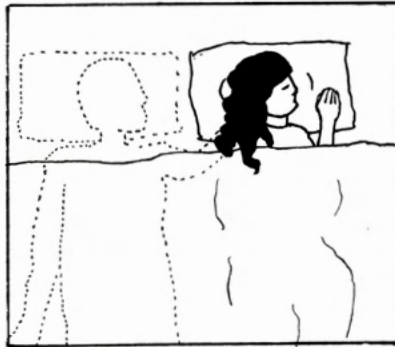
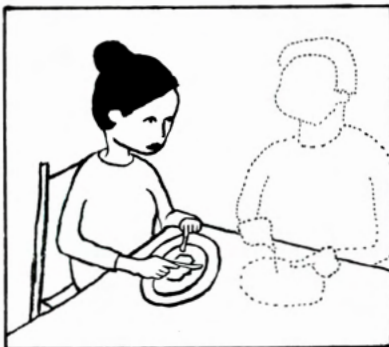
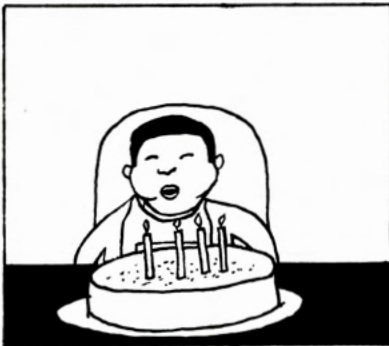

He was put in segregation.

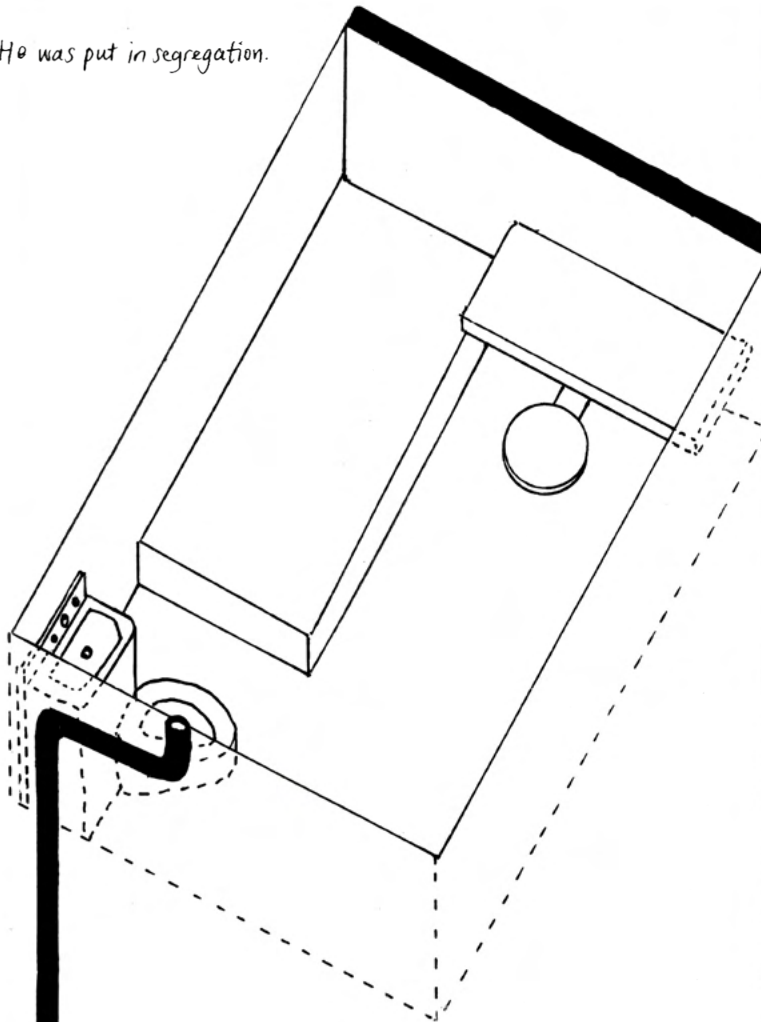

Isolated for up to 23 hours a day people find ways to communicate with other detainees through the walls, through toilet pipes, emptied of water. In 2013, California saw its largest hunger strike of 30,000 inmates in solitary. This mass action was organized over years of such stolen conversations.

According to Corrections Canada, solitary confinement is euphemistically called "administrative segregation," used to ensure the "safety of all inmates, staff, and visitors," rather than for punitive reasons. In the control of bodies, architecture manages risk, so that the system never has to confront the power of inmates.

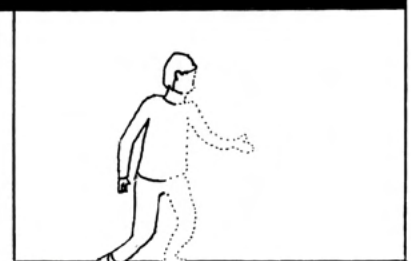

Prisoners held in prolonged segregation speak about the feeling of merging with the walls..5

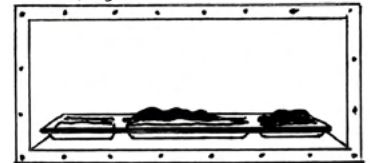

07H: WAKE UP

22H: LIGHTS OUT

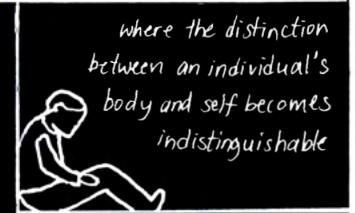

where the distinction between an individual's body and self becomes indistinguishable from the individual cell itself.

Incarceration

Scapegoat 7

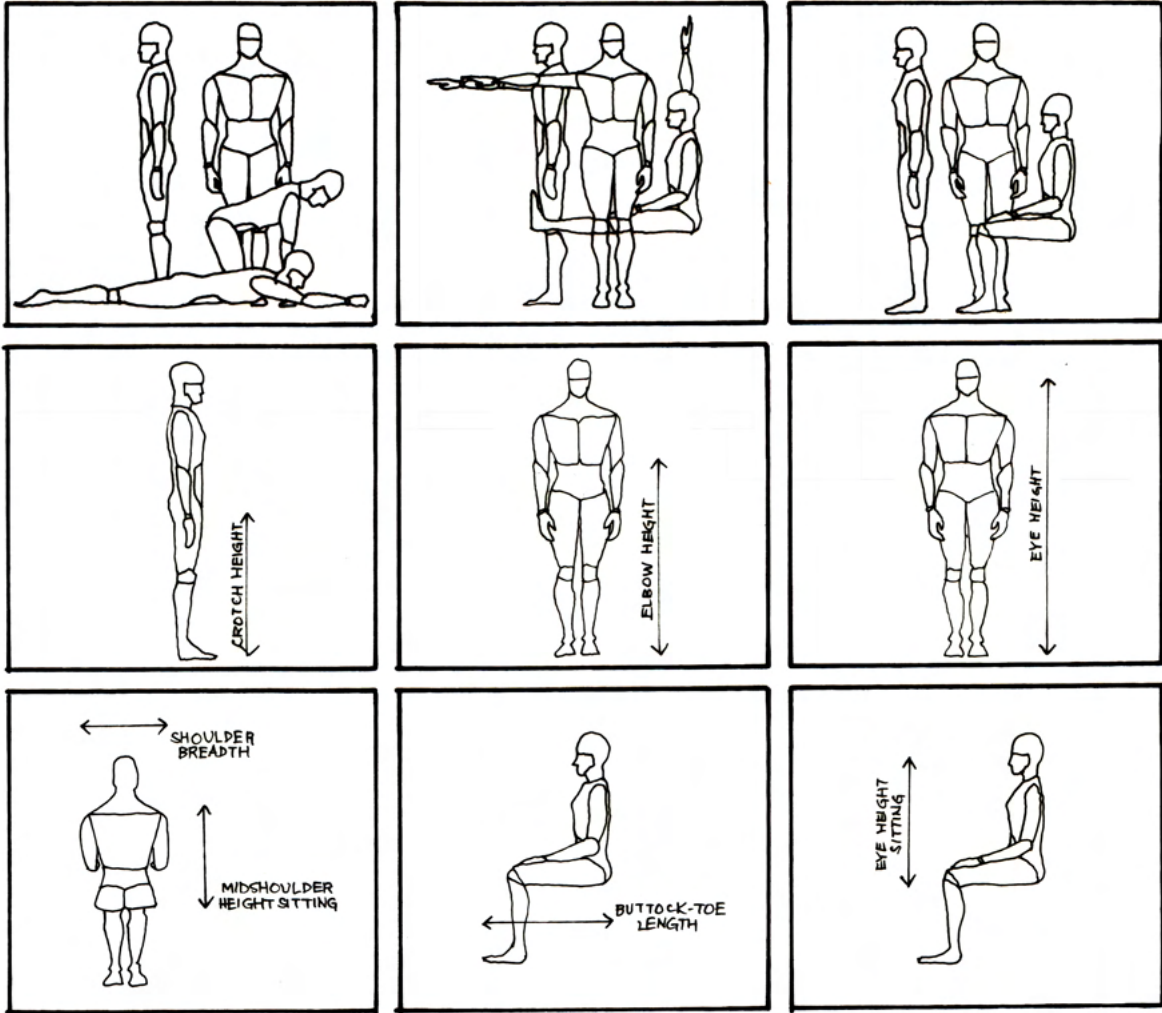

Accordingly, the modern cell is based on the idea of the modern individual, the minimum social unit to which everything is scaled. From the automobile to the micro-condominium, the secure housing unit to the hospital cubicle, our bodies are standardized and our needs, quantified.

Undocumented: The Architecture of Migrant Detention

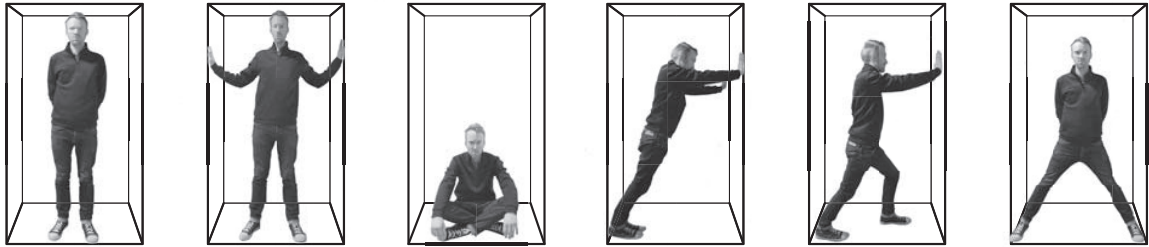

The minimum habitable space for an incarcerated individual is measured.

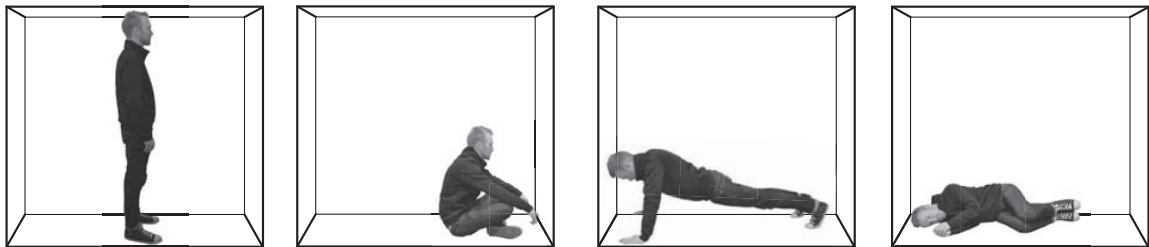

2 square metres of floor area

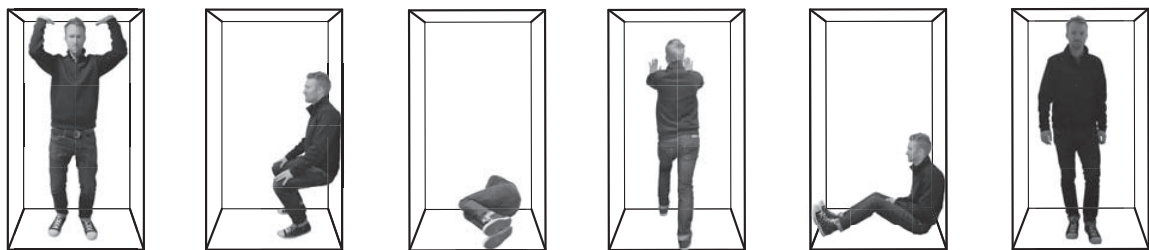

and 3.5 cubic metre of air space.⁶

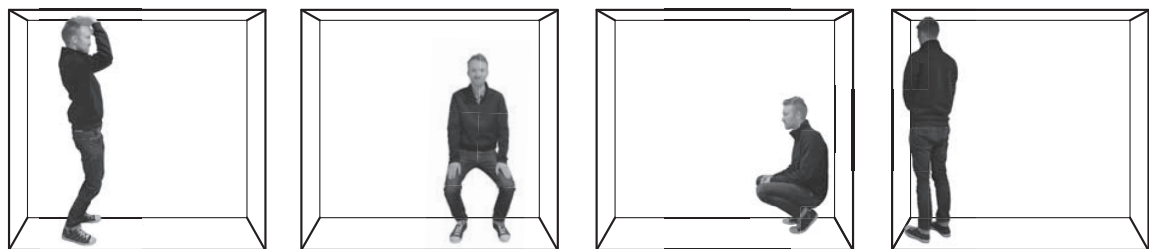

In this volume, the contents of your life are caged. But not every human action can be programmed or predicted, our bodies always find ways to carve out space, to refocus our attention from the geometry to the lived experience, from the container to the contained.

Amongst bolted down stainless steel furniture, cold concrete floors, frosted narrow windows, and under a routine as fixed as the fixtures embedded into the walls, detainees find ways to make space.

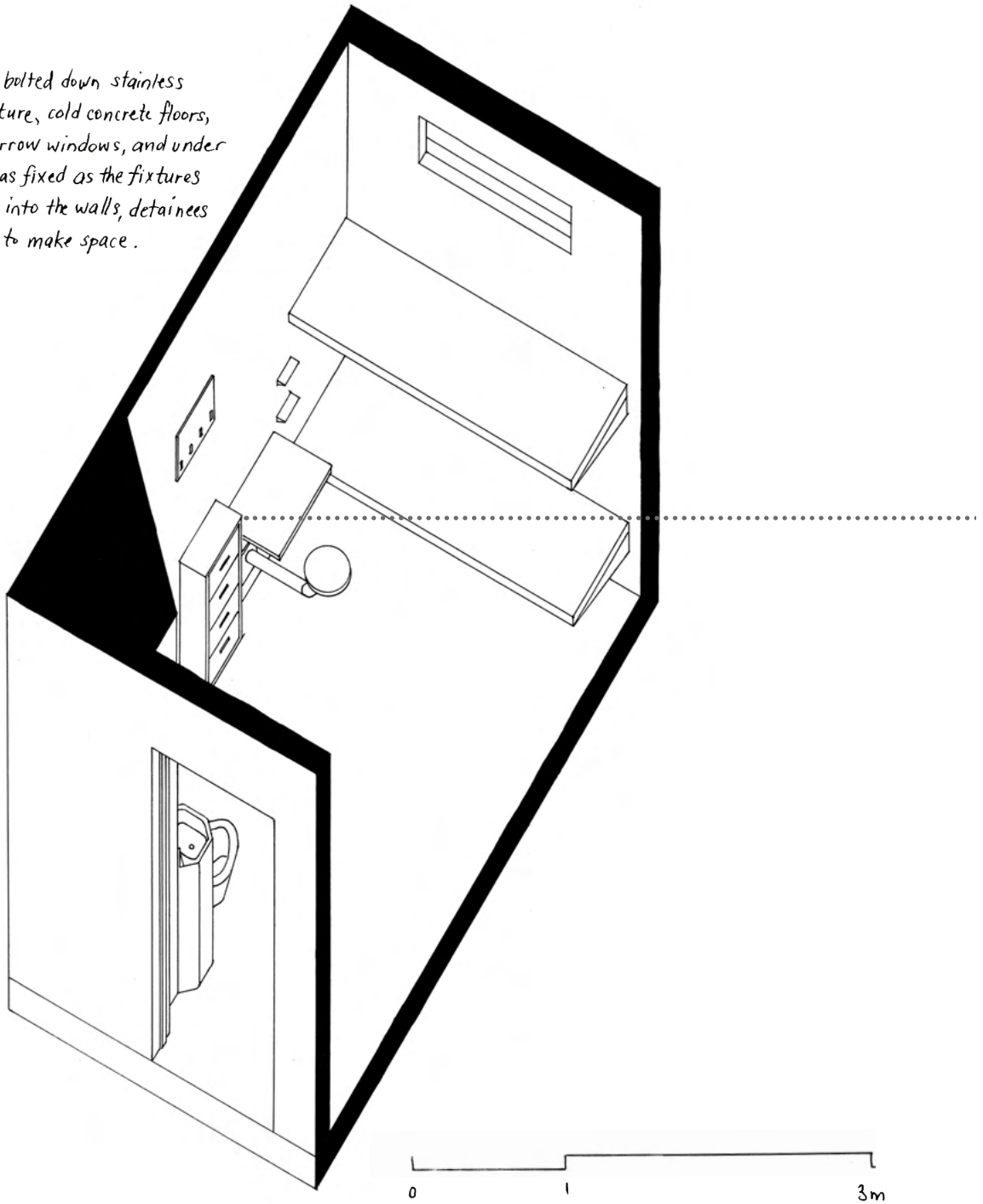

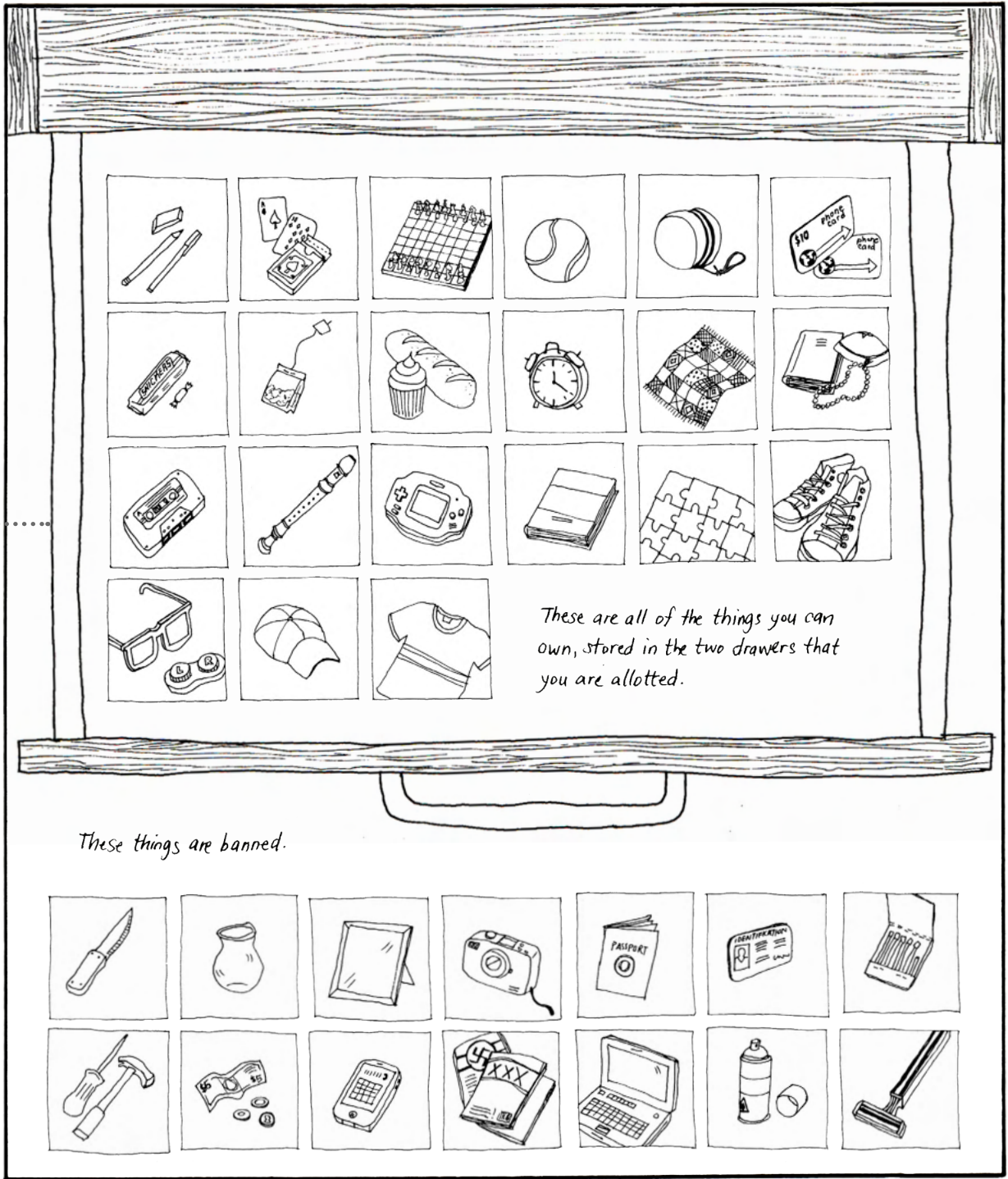

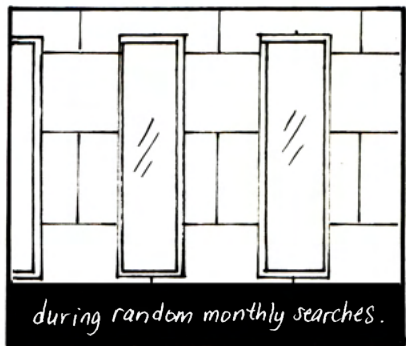
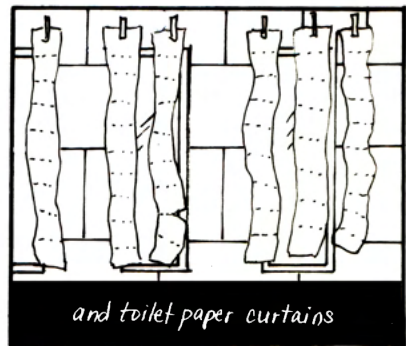
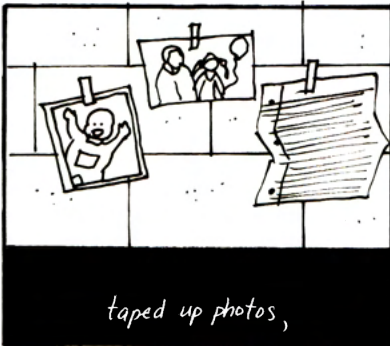
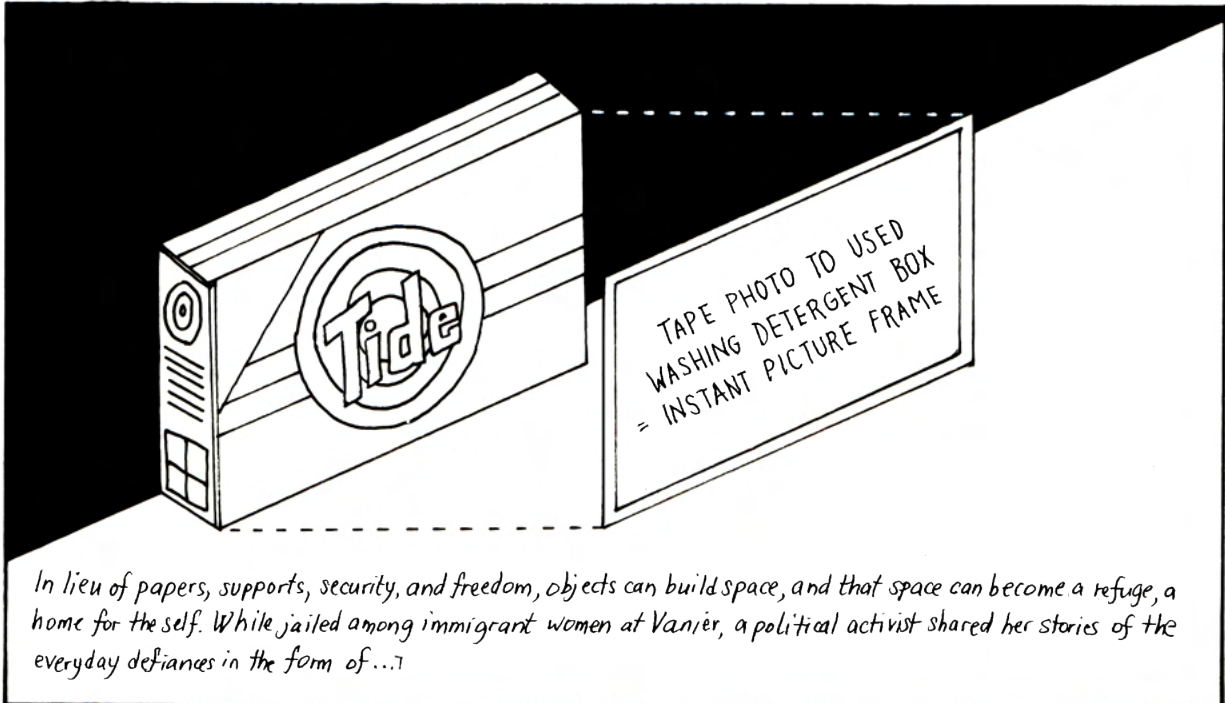

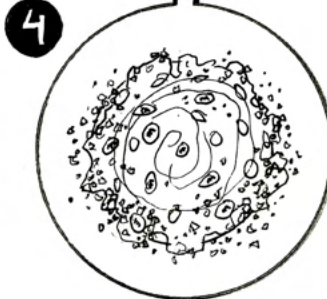
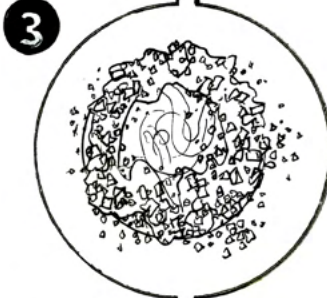
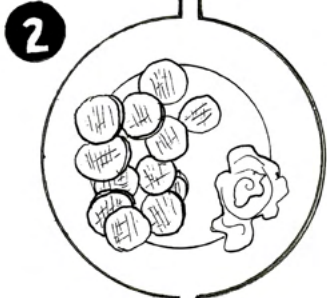

INGREDIENTS:

- 2 plastic bags
- 1 plate
- 2 packages of canteen cookies
- 1 tube/package of peanut butter
- 1 bag of m&ms

DIRECTIONS:

1. get ingredients at weekly canteen
2. separate cream from cookies
3. crush cookies and mix cream with peanut butter
4. layer cookies mixed with water, cream "icing", and sprinkle m&ms on top.

n.b. there are probably no candles in detention

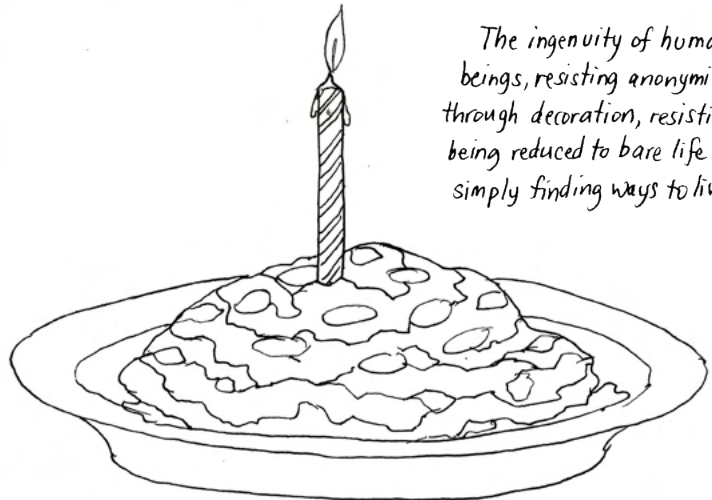

The ingenuity of human beings, resisting anonymity through decoration, resisting being reduced to bare life by simply finding ways to live.

JAIL CAKE to "celebrate" birthdays and those getting released.

Incarceration

Scapegoat 7

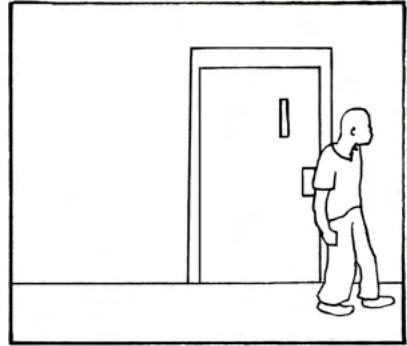
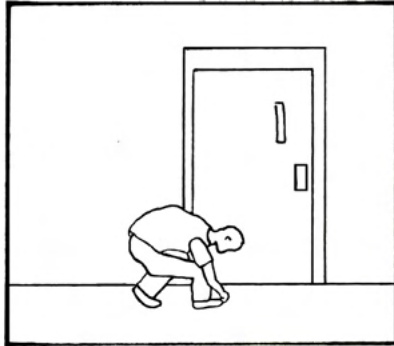
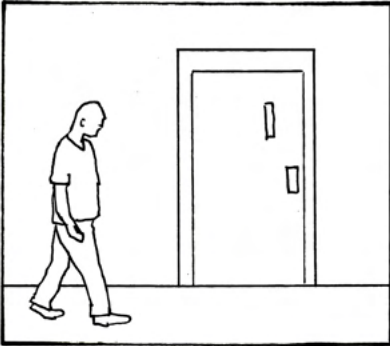

 A large illustration of a book lying flat on a floor. The cover of the book is white with the title "TORANGE D." written in bold, black, sans-serif capital letters. The book has a dark spine and cover.

Just as the architecture sets limits to the body and possible inhabitation, the body imposes limits to architecture's ambitions.

In Violence of Architecture, Bernard Tschumi describes a kitchen as a space of cooking and eating, yet it can also be a space for sleeping, and making love.

This, he calls, programmatic violence.



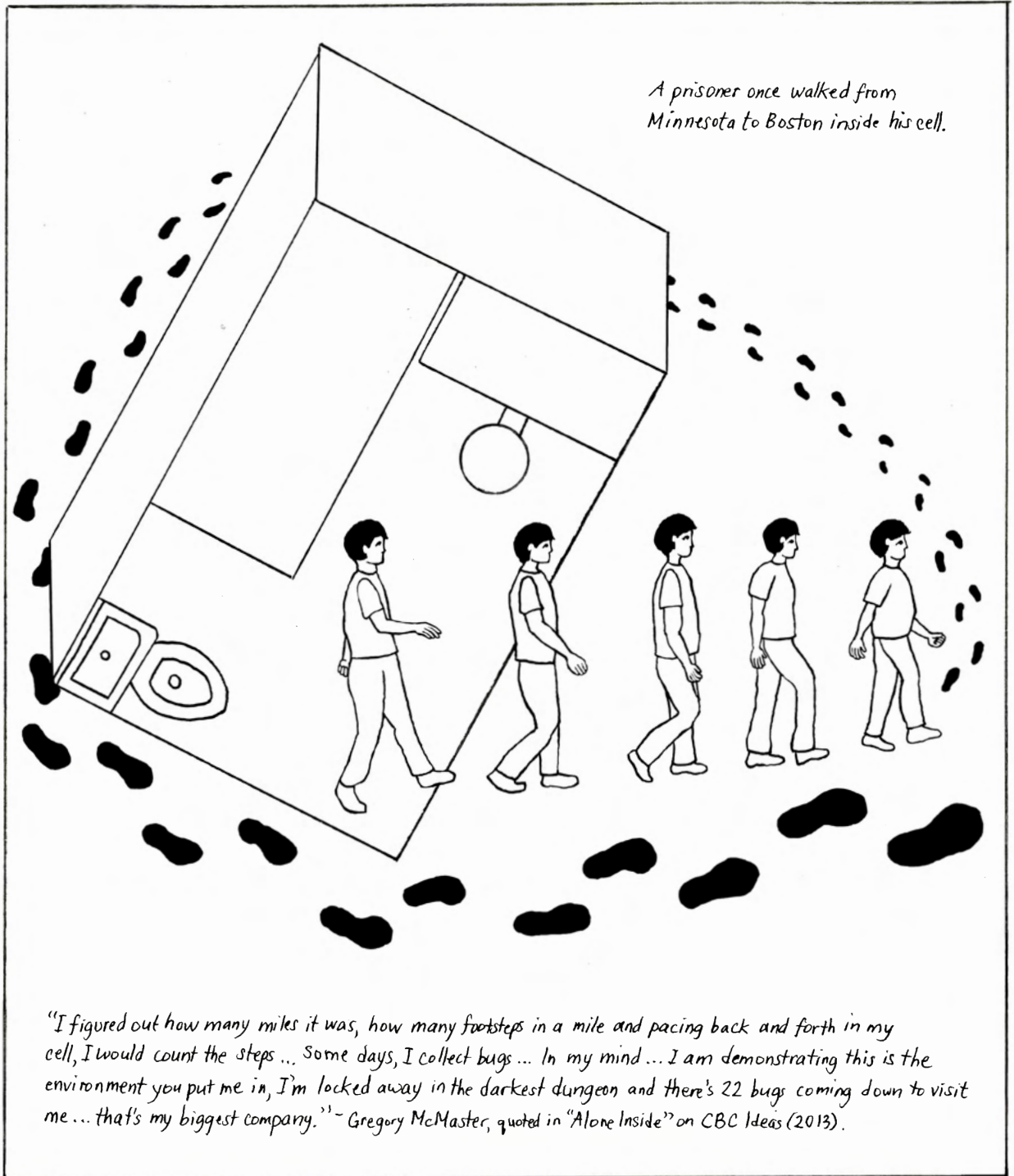



Learn more about the strike and ongoing campaign: www.endimmigrationdetention.com

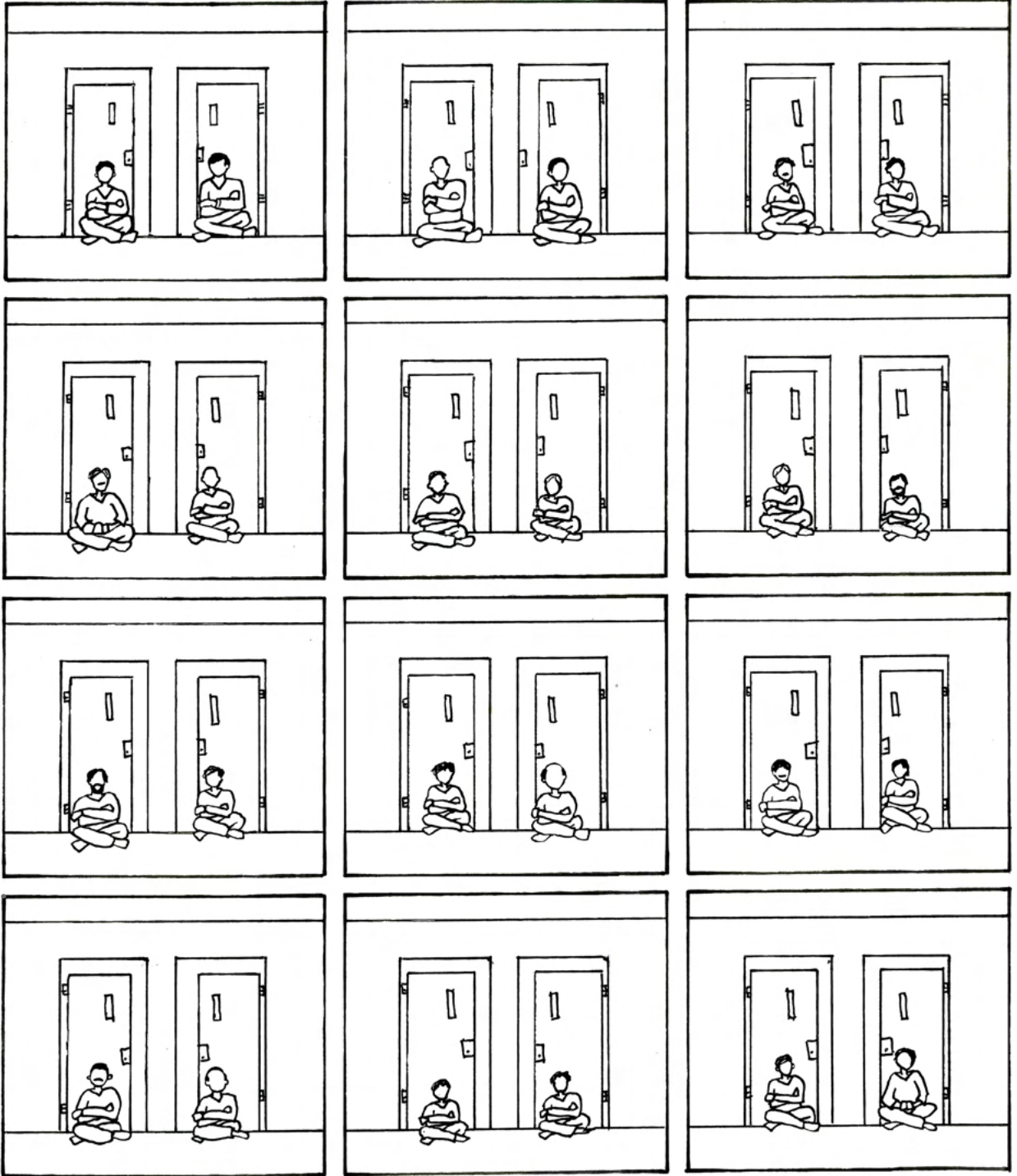

The preceding pages are an excerpt from the recently published book, Undocumented: The Architecture of Migrant Detention (The Architecture Observer, 2014). Every year, thousands of people are detained for administrative/immigration purposes in designated “holding centres” and provincial prisons across the country—they are held indefinitely, without charge or trial. On any given day, hundreds of women, men, and children are locked up, primarily poor people of colour from the global South whose mobility is increasingly criminalized and illegalized. This work draws its inspiration from ongoing migrant justice struggles in solidarity with migrants held in detention in Lindsay, Ontario’s Central East Correctional Centre. Stories are based on collective organizing work through No One Is Illegal—Toronto and the End Immigration Detention Network and research completed for a Master of Architecture thesis at the University of Toronto. For more information about the book and campaign, please visit www.undocumented.ca and www.endimmigrationdetention.com.